

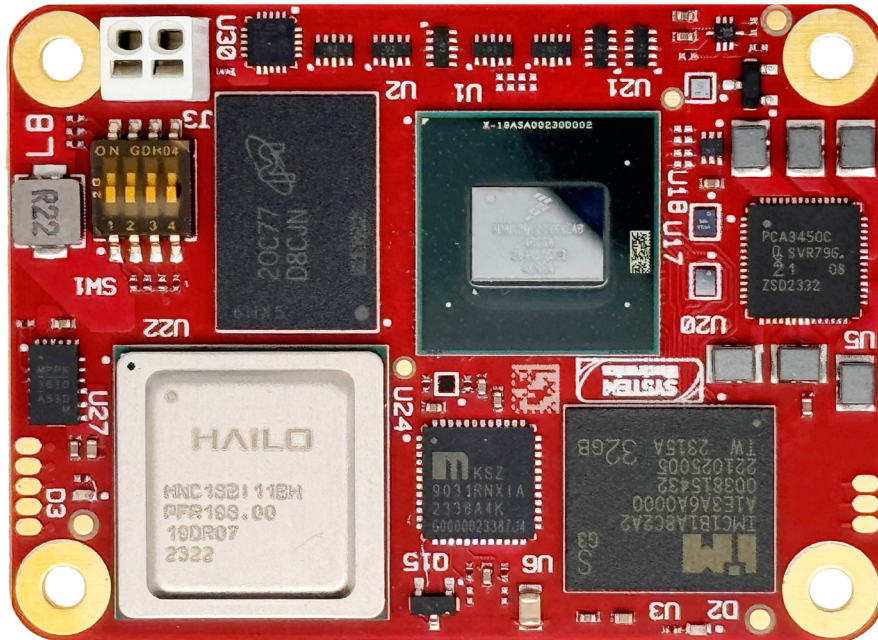

a coesia brand



# Real Time Edge Computing CM4 Board for Industrial Application

Operating guide

**ASTRIAL**  
System Electronics for AI Innovation



a coesia brand



**SYSTEM CERAMICS s.p.a. B.L. SYSTEM ELECTRONICS**

Via Ghiarola Vecchia, 73

41042 Fiorano (MO) - Italy

[www.system-electronics.it](http://www.system-electronics.it)

e-mail: [info@system-electronics.it](mailto:info@system-electronics.it)

[Systemelectronics.ai](mailto:info@system-electronics.it)

Revision	Revision history	Pages
00	Draft	-
01	Note inserted at the end of the page	3-6
02	<ul style="list-style-type: none"><li>• new product image</li><li>• multiple par. changes</li><li>• Astrial Block Diagram table</li></ul>	Cover, II, III, 1-2, 3-2, 3-3, 3-4, 3-5, 3-6, 3-7, 3-11, 3-16, 3-17, 3-18, 3-19, 3-20, 3-22, 5-1, 5-2, 6-1



a coesia brand

This manual applies to the product codes:

Description	PN SAP	PN supplier
Astrial Industrial	ASTRIALC8H0832IA	2E001866
Astrial Commercial	ASTRIALC8H0832CA	2E001867

Publication issued by: SYSTEM CERAMICS S.p.A. B.L. SYSTEM ELECTRONICS

Revision: 02 of 10/2024

© 2024 - All rights reserved

Translation of the original instructions: English

**DISCLAIMER**

All information in this manual is correct at the time of publication.

The contents of this manual are subject to change without notice.

SYSTEM CERAMICS S.p.A. B.L. SYSTEM ELECTRONICS assumes immeasurable liability for technical or editorial errors in this document only in cases of gross negligence or culpable personal injury. It otherwise does not assume such liability to the extent permitted by law. Liability in cases where the law provides for mandatory unlimited liability (such as product liability), however, remains the same. Liability is excluded in the case of business interruption, indirect damage, consequential damage, loss of profit or loss of information and/or data, in particular for damage directly or indirectly attributable to the supply, performance and use of this product.

SYSTEM CERAMICS S.p.A. B.L. SYSTEM ELECTRONICS notes that the software and hardware names and brand names of the respective companies used in this document are subject to the general protection of trademarks or patents.

The hardware and software of third-party providers referred to herein are subject exclusively to the respective terms of use of those third-party providers.

SYSTEM CERAMICS S.p.A. B.L. SYSTEM ELECTRONICS accepts no liability whatsoever for the contents of this document. Any recommendations made by SYSTEM CERAMICS S.p.A. B.L. SYSTEM ELECTRONICS are not contractual content, but merely non-binding information for which no liability is accepted. When using hardware and software of third-party providers, the relevant user documentation of these third-party providers must also be consulted and, in particular, the safety guidelines and technical specifications contained therein must be observed.

The compatibility of SYSTEM CERAMICS S.p.A. B.L. SYSTEM ELECTRONICS products described in this document with hardware and software of third-party providers does not constitute contractual content, unless this has been agreed separately in individual cases; in this regard, however, the guarantee of such compatibility is excluded, and it is the sole responsibility of the customer/user to check such compatibility in advance.

This product meets the safety requirements of the following standards:

- Directive 2014/35/EU Electrical equipment designed for use within certain voltage limits: (LDV).
- Directive 2014/30/EU: Electromagnetic compatibility: (EMC).  
Harmonised standard Immunity of industrial devices: CEI EN 61000-6-2
- Harmonised standard Emission of industrial devices: CEI EN 61000-6-4
- Directive 2011/65/EU. Restricted use of certain hazardous substances in electrical and electronic equipment: (RoHS2)
- Directive 2015/863/EU amending Annex II of Directive 2011/65/EU as regards the list of restricted substances: (RoHS3)
- REGULATION (EU) 2023/988. General product safety
- REACH REGULATION (EU) No.1907/2006. General product safety



# Contents

<b>1. General information</b>	<b>1-1</b>
1.1 Introduction	1-1
1.2 Safety warnings and reference notes	1-1
1.3 Availability	1-2
1.4 Technical support	1-2
<b>2 Safety information</b>	<b>2-1</b>
2.1 Safety regulations	2-1
2.2 Exclusion of liability	2-1
2.3 Non-Compliant and Non-Permitted Uses	2-1
2.4 Warnings and precautions	2-2
2.5 Damage to the product caused by magnetic fields or electrostatic discharges	2-2
<b>3. Description and technical data</b>	<b>3-1</b>
3.1 Intended use	3-1
3.2 Characteristics	3-1
3.3 Product overview	3-2
3.4 Interfaces	3-3
3.4.1 Ethernet	3-3
3.4.2 USB 2.0 (high speed)	3-4
3.4.3 USB 3.0	3-5
3.4.3.1 EdgeLock SE050	3-6
3.4.4 GPIO	3-7
3.4.4.1 i.MX8M Plus Boot Mode	3-8
3.4.4.2 Astrial Block Diagram	3-9
3.4.4.3 Alternative function assignments	3-10
3.4.4.4 HDMI 2.0	3-19
3.4.4.5 CSI-2 (MIPI serial camera)	3-19
3.4.4.6 DSI-2 (MIPI serial camera)	3-19
3.4.4.7 I2C (SDA0 SCL0)	3-19
3.4.4.8 I2C (ID_SD ID_SC)	3-20
3.4.4.9 SDIO/eMMC (32Gb eMMC memory)	3-20
3.4.4.10 Analogue IP0/IP1	3-21
3.4.4.11 RPI_BOOT_N	3-21
3.5 Mechanical and electrical specifications	3-22
3.5.1 Mechanical	3-22
3.5.2 Thermal protection	3-23
3.5.3 Electrical specifications	3-24
3.5.4 Note on the use of Astrial	3-24
<b>4. Reception and storage of the product</b>	<b>4-1</b>
4.1 Checking the content	4-1
4.2 Storage	4-1
4.3 Assembly and disassembly	4-2

- 5. Connections ..... 5-1**
  - 5.1 Safety instructions.....5-1
  - 5.2 Lengths of the differential torque signal from 100 Ω clearance distances .....5-1
  - 5.3 Lengths of the differential torque signal from 90 Ω .....5-2
  
- 6. Operating Instructions ..... 6-1**
  - 6.1 Switch-on sequence .....6-1
  - 6.2 Switch-off sequence .....6-1
  - 6.3 Energy consumption .....6-1
  - 6.4 Regulator outputs .....6-2
  - 6.5 Hailo 8.....6-2
  - 6.6 Software .....6-2
  
- 7. Maintenance and disposal ..... 7-1**
  - 7.1 Routine maintenance .....7-1
  - 7.2 Decommissioning and disposal .....7-1

# 1. General information

## 1.1 Introduction

Thank you for choosing ASTRIAL: Development module in CM4 format for Real Time Edge Computing applications, which can also be used in an industrial environment. Please read this manual and keep it with care. The information it contains will be indispensable for correct installation and safe use. With this manual, SYSTEM ELECTRONICS wishes to establish a cooperative relationship with you in order to perfect our product to make it more versatile for your needs. That is why we kindly ask you to notify us of any errors, oversights, malfunctions, suggestions, comments, opinions, by writing to the contacts you will find in this manual.

System Electronics, a brand of the Coesia Group, enters the world of AI with ASTRIAL, a community-inspired technology platform for the industrial environment.

The new artificial intelligence-based solution for industrial applications from System Electronics.

## 1.2 Safety warnings and reference notes

### DANGER!

*It indicates situations of danger for people and recalls accident prevention regulations.  
Failure to comply with these safety instructions puts people's lives and health at risk*

### WARNING!

*It notifies personnel of their duties and suggests behavioural procedures to avoid dangerous situations that may become the cause of accidents at work.  
Failure to comply with these safety instructions puts people's lives and health in danger*

### CAUTION!

*It indicates situations of danger for the product or the machine into which the Module is integrated that may become the cause of accidents at work.  
Failure to comply with these instructions puts people's health at risk and/or can cause damage to the environment.*

### NOTES

*Warnings for smooth operation.  
Failure to comply with these instructions may result in damage to the person, product and/or system into which the Module is integrated*

## 1.3 Availability

For the documentation, see [System Electronics.ai](#)

## 1.4 Technical support

EBV, as an authorised reseller of Astrial product, is available for a first level contact to customer and for any additional information or clarification required.

If necessary, please contact (sito EBV)

In case of deeper technical expertise support is needed, the manufacturer support service is available for clarification or contact and intervention by specialists.

Always specify:

- Customer's name and identification data;
- The product identification data, such as: code and model.

If necessary, please contact:

**SYSTEM CERAMICS s.p.a. B.L. SYSTEM ELECTRONICS**

Via Ghiarola Vecchia, 73

41042 Fiorano (MO) - Italy

[www.system-electronics.it](http://www.system-electronics.it)

e-mail: [info@system-electronics.it](mailto:info@system-electronics.it)

[Systemelectronics.ai](http://Systemelectronics.ai)

### NOTES

*Always purchase original or equivalent spare parts if authorised in writing by SYSTEM ELECTRONICS*



## 2 Safety information

### 2.1 Safety regulations

Operate in compliance with the information in the manual and the safety measures: failure to comply may result in serious personal injury and/or damage to property! Respect the safety instructions and all the specifications in this manual.

This is a prerequisite for safe, trouble-free operation and for achieving the specified product characteristics.

### 2.2 Exclusion of liability

SYSTEM ELECTRONICS Products are supplied in particular hardware and software configurations adapted to the type of application required.

Modifications to the configurations of the hardware or software other than those described in the manual are not permitted.

Any changes not covered in this manual exempt SYSTEM ELECTRONICS from liability.

### 2.3 Non-Compliant and Non-Permitted Uses

#### NOTES

*This information has been prepared with care. However, the instructions described are constantly being revised as needed.*

*We reserve the right to revise and change the procedures and documentation at any time and without notice. No claims can be made for changes to the information, illustrations and descriptions in this manual.*

The ASTRIAL must NOT be used, even partially, under one or more of the following conditions:

- in explosive atmospheres;
- in an environment other than the one provided for in the manual;
- if it has not been correctly installed;
- for a use other than that stipulated by SYSTEM ELECTRONICS;
- under dangerous conditions or if there are malfunctions;
- for uses contrary to the specific regulation;
- in case of electricity supply defects;
- after modifications or interventions not authorised by SYSTEM ELECTRONICS;
- by unqualified personnel;
- in case of a partial or total non-compliance with the instructions;
- to perform operations that were not reasonably foreseeable;
- if there is a lack of maintenance.

#### WARNING!

*SYSTEM ELECTRONICS cannot be held liable for loss of property, damage to equipment and personal injury resulting from installation or use NOT in accordance with the instructions in this manual.*

## 2.4 Warnings and precautions

### CAUTION!

*Direct contact with Astrial when powered does not cause personal injury; however, it is forbidden to touch the Module, particularly with wet hands, or to perform any type of intervention in the presence of electrical voltage.*

### CAUTION!

*Do not attempt to repair the defective Module.  
Only SYSTEM ELECTRONICS personnel are authorised to carry out repairs or unscheduled maintenance.*

## 2.5 Damage to the product caused by magnetic fields or electrostatic discharges

Electric fields or electrostatic discharges create an electrostatic hazard (ESD: Electrostatic Sensitive Device) which can damage individual components, integrated circuits, equipment or devices and consequently cause malfunctions.

### CAUTION!

*For transport and shipping, use packaging materials that can protect the product e.g. conductive foam or aluminium foil.*

*For storage, keep the product in its original packaging.*

*Before touching the Module, one of the following measures must be taken to isolate it:*

- *wear an ESD wristband;*
- *wear ESD shoes or ESD straps for earthing in ESD areas with conductive floors;*
- *place the components or equipment on conductive surfaces.*

## 3. Description and technical data

### 3.1 Intended use

Astrial is a SOM (System on Module) developed for designs that are extremely demanding in terms of computational capacity and power density. It stands out on the market for its unique combination of CM4 format, Hailo 8 accelerator and iMX8M plus microcontroller integrated in an exceptionally compact device. This combination offers high computing power in a format compatible with a wide range of development systems already available on the market. Moreover, Astrial's added value lies in the choice of industrial-grade components designed to withstand the stresses of production environments, and in the long-term support offered to customers.

Data are processed directly in the Astrial SOM, a solution known as Edge Computing, which is becoming increasingly popular due to its advantageous implications in terms of performance, security and latency.

Incorporating artificial intelligence solutions directly into industrial machines offers several advantages:

1. faster data analysis, leading to a reduction in the need to transmit large amounts of data to the cloud for processing;
2. lower latency and higher overall efficiency of the system;
3. increased data security. Potential vulnerability points and opportunities for cyber-attacks are minimised by reducing the amount of data transmitted through external networks.



### 3.2 Characteristics

The main features of Astrial are:

- NXP i.MX8M Plus, 4xCortex-A53 @1.6GHz with 2.3TOPS and a GPU with OpenVG 1.1, G2D, OpenGL®ES3.1, OpenCL™ 1.2FP
- 8 Gbyte LPDDR4 32-bit RAM, 32 Gbyte eMMC
- Small Footprint 55mm × 40 mm × 4.7 mm module
  - 4 × M 2.5 mounting holes
- H. 265 (HEVC) (up to 4Kp60 decode), H. 264 (up to 1080p60 decode, 1080 p 30 encode)
- OpenGL ES 3.0 graphics
- Gigabit Ethernet PHY KSZ9031RNX
- 1 × USB 2.0 port (high speed)
- 28 × GPIOs supporting either 1.8V or 3.3V signalling and peripheral options:
  - Up to 2 × UART
  - Up to 3 × I2C
  - Up to 2 × SPI
  - 2 × SDIO interface
  - 1 × CANbus
  - 1 × PCM
  - 1 × PWM channel
- 1 × HDMI 2.0 ports (up to 4Kp 60 supported)
- MIPI DSI:
  - 1 × 4 - lane MIPI DSI display port
- MIPI CSI-2:
  - 1 × 2 - lane MIPI CSI camera port
  - 1 × 4 - lane MIPI CSI camera port
- 1 × SDIO 2.0
- Single + 5V PSU input.

### 3.3 Product overview

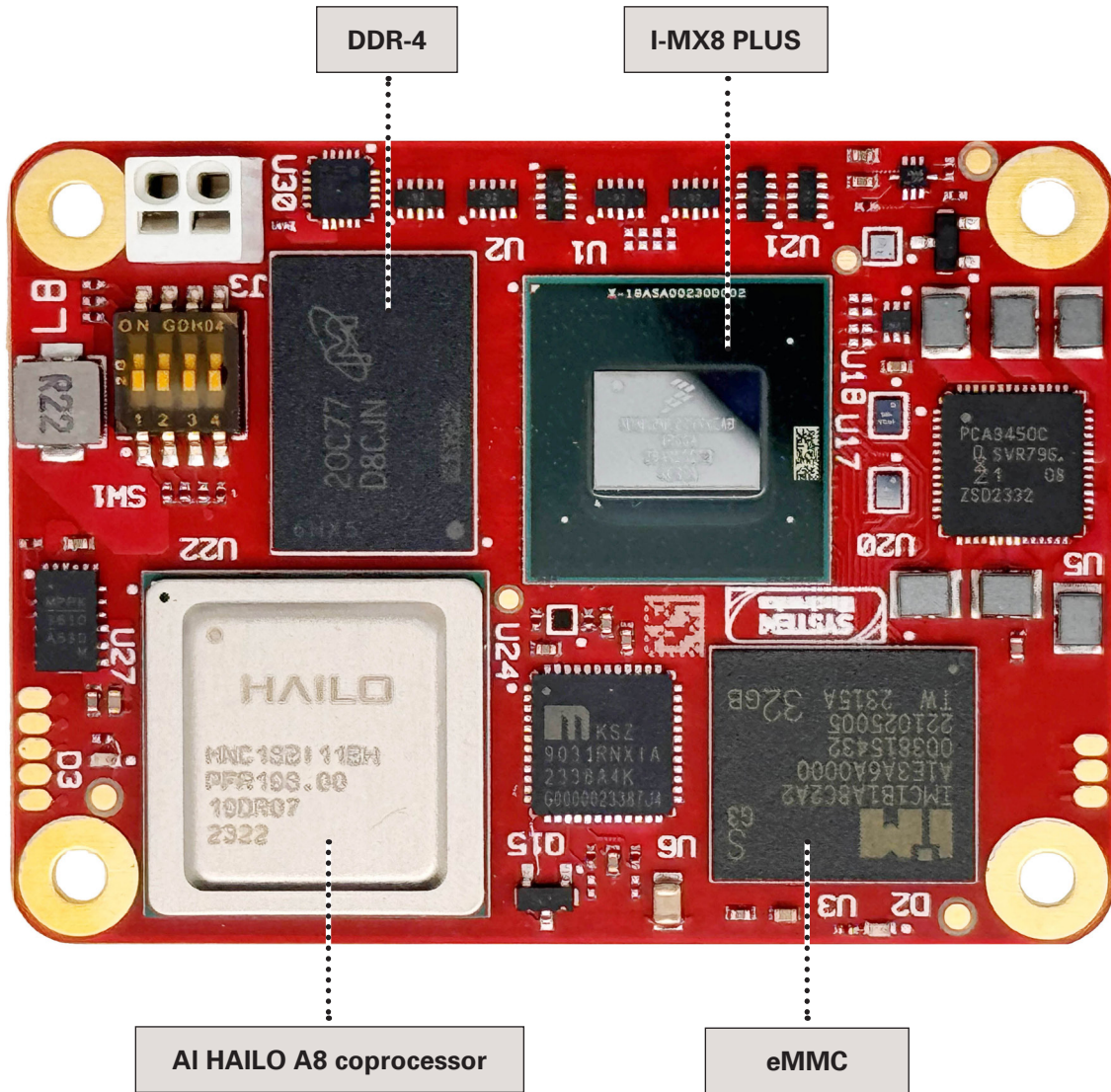

### 3.4 Interfaces

#### 3.4.1 Ethernet

ASTRIAL features the integrated Gigabit Ethernet PHY - Microchip KSZ9031RX and its main features include:

- MDI crossover, pair skew and torque polarity correction

Standard MagJack RJ45 1:1 provides an Ethernet connection to the module. Figure 4.1 shows its typical wiring that supports PoE and has additional ESD protection.

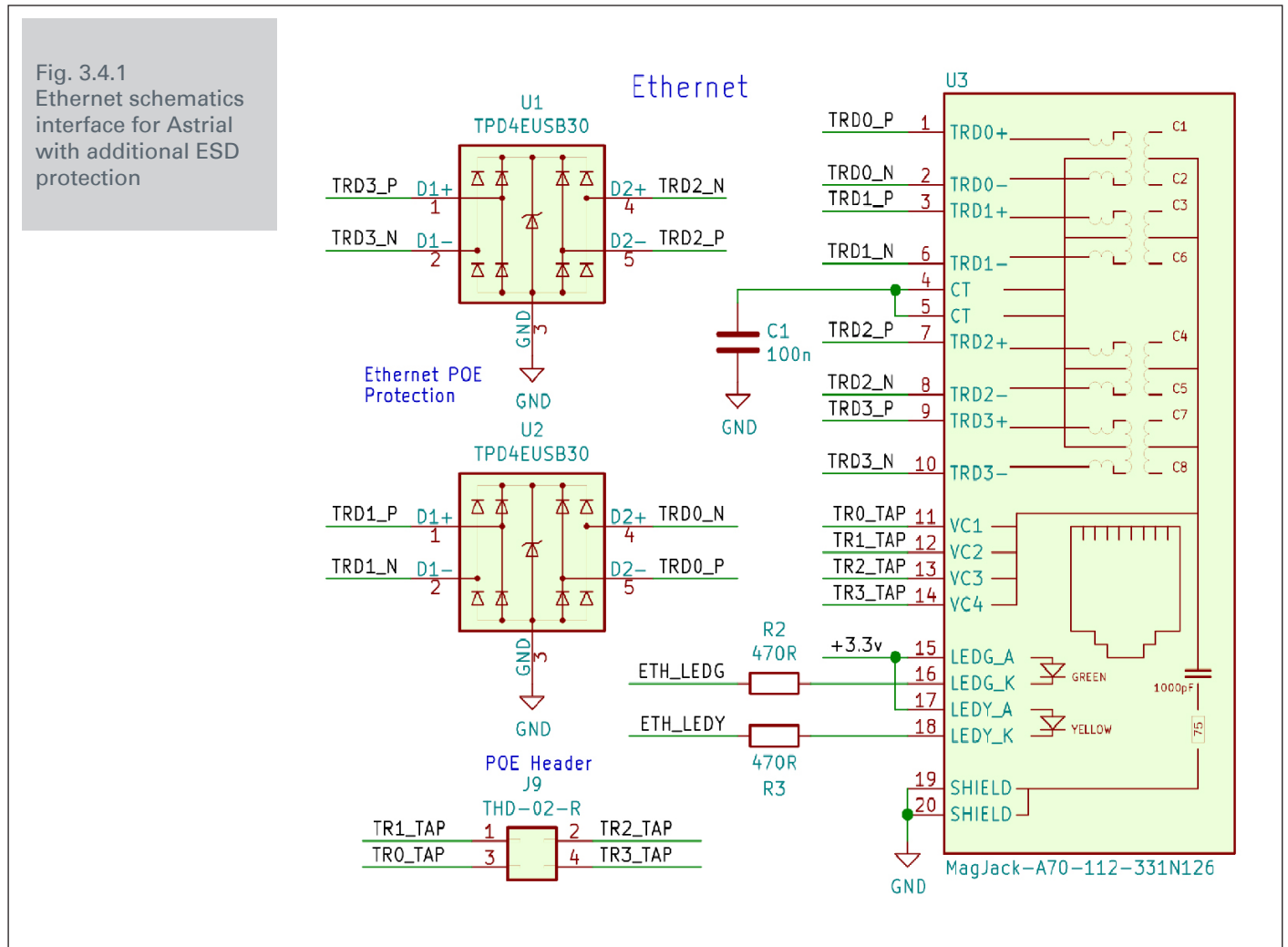

Differential Ethernet signals must be routed as 100 Ω differential pairs, with appropriate clearances. The length match between pairs must be better than 50 mm; no length match is required in the typical case. However, signals within a pair must be matched in length, ideally with a match smaller than 0.20 mm. The PHY also supports up to 2 LEDs to provide feedback on user status; these are active low. The LEDs can have a range of functions. Refer to the driver of your operating system to see which functions are supported. The ASTRIAL module also provides 3.3 V SYNC\_IN and SYNC\_OUT signalling to support the IEEE 1588-2008 protocol.

### 3.4.2 USB 2.0 (high speed)

The USB 2.0 interface supports signalling up to 480 Mbps. The differential pair should be routed as a 90  $\Omega$  differential pair. The length of the P/N signals should be matched to a value greater than 0.15 mm.

#### NOTES

*The port can be used as a true USB On-The-Go (OTG) port.*

*In particular, the hardware configuration provides that the USB\_OTG\_ID pin, if connected to the pull-up resistor, will allow Astrial to work as a DEVICE HUB; conversely, if USB\_OTG\_ID is connected to the pull-down resistor, it will make Astrial assume the HOST configuration.*

*For the development of customised CM4 carriers compatible with Astrial, please contact SYSTEMELECTRONICS.*

### 3.4.3 USB 3.0

The USB 3.0 interface supports signalling up to 5 Gbps. The differential pair should be routed as a 90 Ω differential pair. The length of the P/N signals should be matched to a value smaller than 0.20 mm.

USB 3.0 is not compatible with the USB 3.0 lines of the CM4 standard; it is an additional feature designed by System Electronics and exploits part of the PCI Express lines to achieve the typical transmission speed of 5 Gbps. The circuit image below shows the USB 3.0 lines.

If the USB 3.0 peripheral is to be used, you are advised to contact SYSTEM ELECTRONICS to request a specific carrier board.

Please refer to ASTRIAL's circuit diagram for further information.

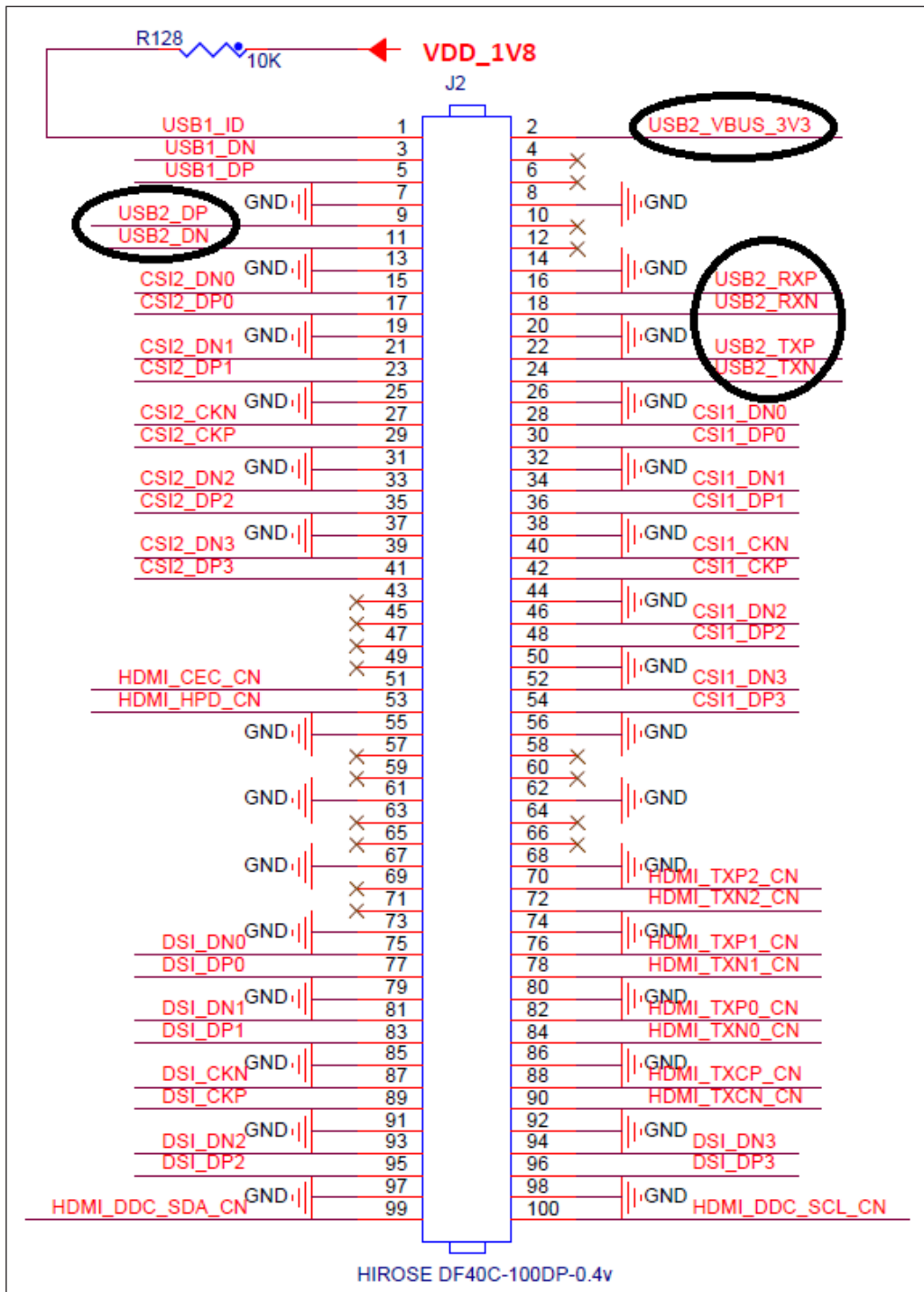

### 3.4.3.1 EdgeLock SE050

The EdgeLock SE050 secure element (SE) product family offers advanced EAL 6+ and FIPS 40-2 certified security for strong protection against the latest hacker attack scenarios, as well as an extended feature set for a wide range of use cases for IoT applications.

This off-the-shelf security chip for IoT devices provides end-to-end protection - from the edge to the cloud - without the need to implement a security code or manage critical keys and credentials.

Main advantages:

Plug & Trust for quick and easy design with full product support package and example codes for a wide range of use cases.

Extended user memory with dynamic file system to store credentials for multiple applications running on a chip. Compliant with many security standards such as IEC 62443, DLMS/COSEM, OPC-UA and ISO15118-2 End-to-end security, from the edge to the cloud.

Trusted anchor for IoT devices with secure credential injection at the hardware level.

The Edgelock is connected to i.MX8M Plus through the I2C3\_SDA and I2C3\_SCL pins.

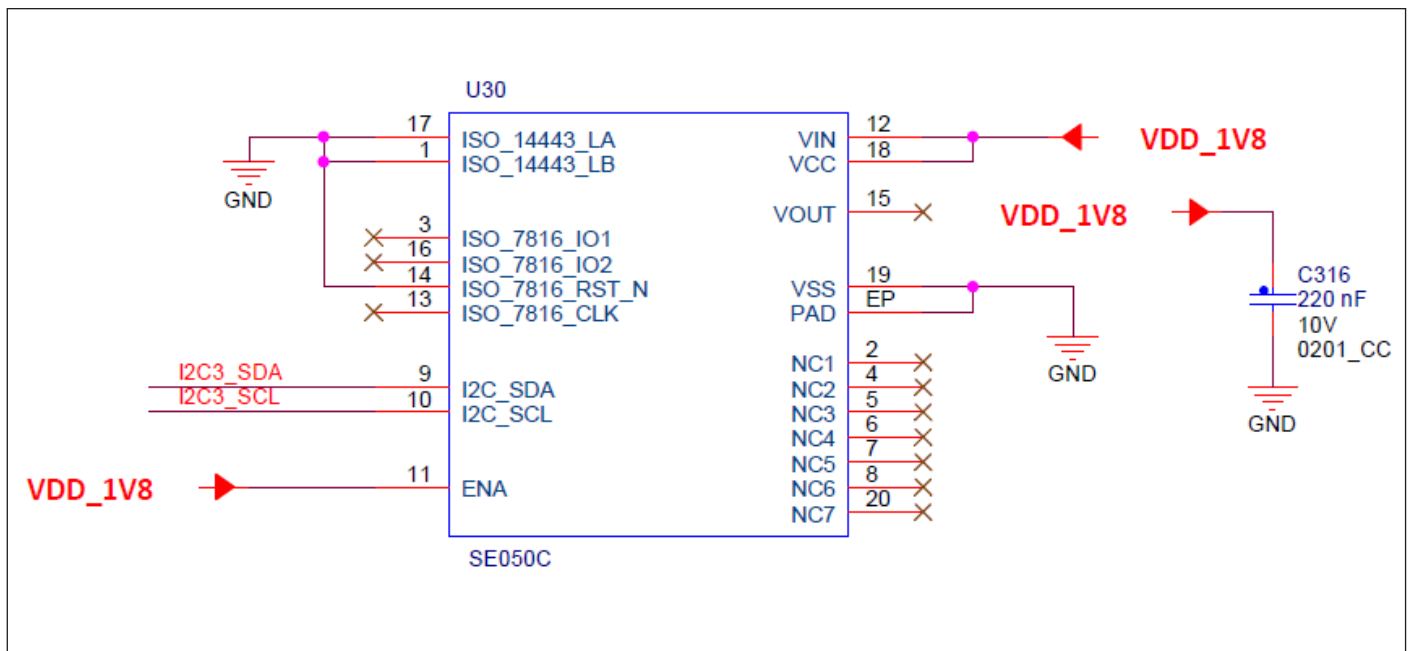

#### NOTES

*The EdgeLock SE050 is only present on Astrial industrial version, the commercial version does not include the chip SE050*



### 3.4.4 GPIO

There are 28 pins for general purpose I/Os (GPIOs), on the 40-pin connector of the CM4 I/O common carrier. These pins have access to internal peripherals: SMI, DPI, I2C, PWM, SPI and UART.

The NXP i.MX8M Plus peripheral manual describes these features in detail, together with the available multiplexing options.

GPIO2 and GPIO3 have 1.8 k $\Omega$  pull-up resistors.

The GPIO bank of the i.MX8M Plus is powered by GPIO\_VREF, which can be connected to either +1.8 V for 1.8 V GPIO signalling or +3.3 V for 3.3 V signalling.

In this case, the load on the 28 GPIO pins should be kept below 50 mA total, and GPIO\_VREF must be powered for the module to start correctly.

### 3.4.4.1 i.MX8M Plus Boot Mode

Astrial, in PCB 3.0, integrates a dip switch that allows, among the various permissible configurations, the management of different boot modes from SD card or eMMC.

For more details, please refer to the image below or consult the Astrial PCB 3.0 circuit diagram

#### Note

The only allowed configurations are the following:

#### i.MX8M Plus Boot Mode

BOOT_MODE3 DIP_Switch_3	BOOT_MODE2 DIP_Switch_2	BOOT_MODE1 DIP_Switch_1	RPIBOOT_N (PIN93) DEFAULT=1	Boot Modes
0	0	0	0	Boot From Internal i.MX8M Fuses
0	0	0	1	USB Serial Download
0	0	1	0	USDHC3 (eMMC boot only, SD3 8-bit) Default
0	0	1	1	USDHC2 (SD boot only, SD2)
0	1	1	0	QSPI 3B Read *
0	1	1	1	QSPI Hyperflash 3.3V *
1	0	0	0	ecSPI Boot *

(\*) Those configurations have not been tested in this preliminary release

#### Caution:

BOOT\_MODE0, BOOT\_MODE1, BOOT\_MODE2, BOOT\_MODE3, JTAG\_MOD and POR\_B must be pulled to "11111" for i.MX8M Plus to enter Boundary Scan mode.

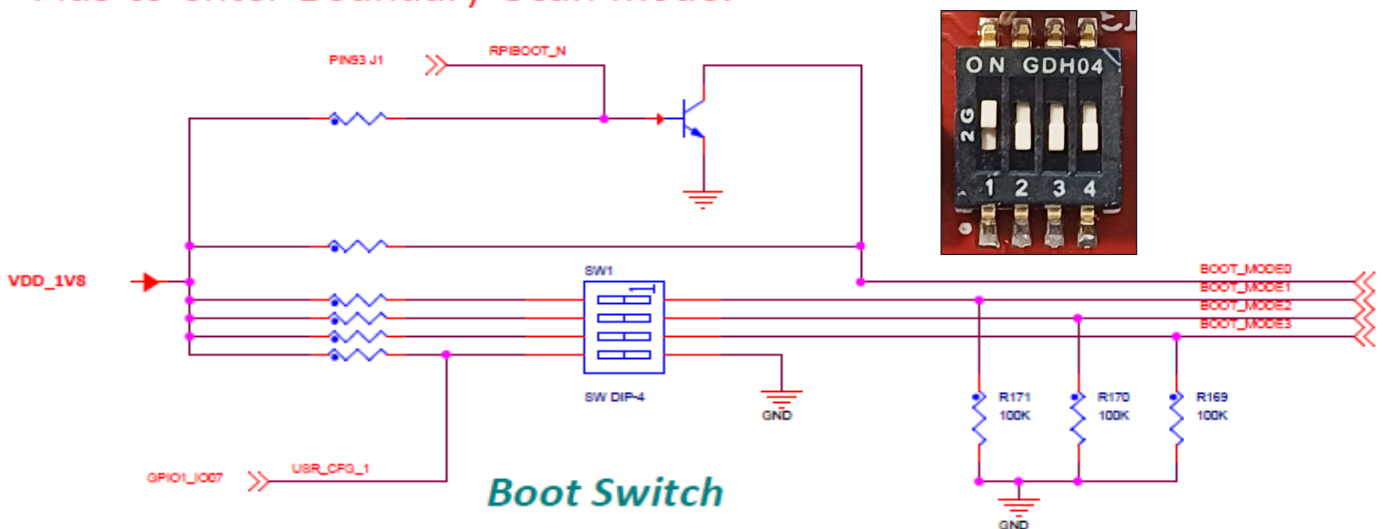

### 3.4.4.2 Astrial Block Diagram

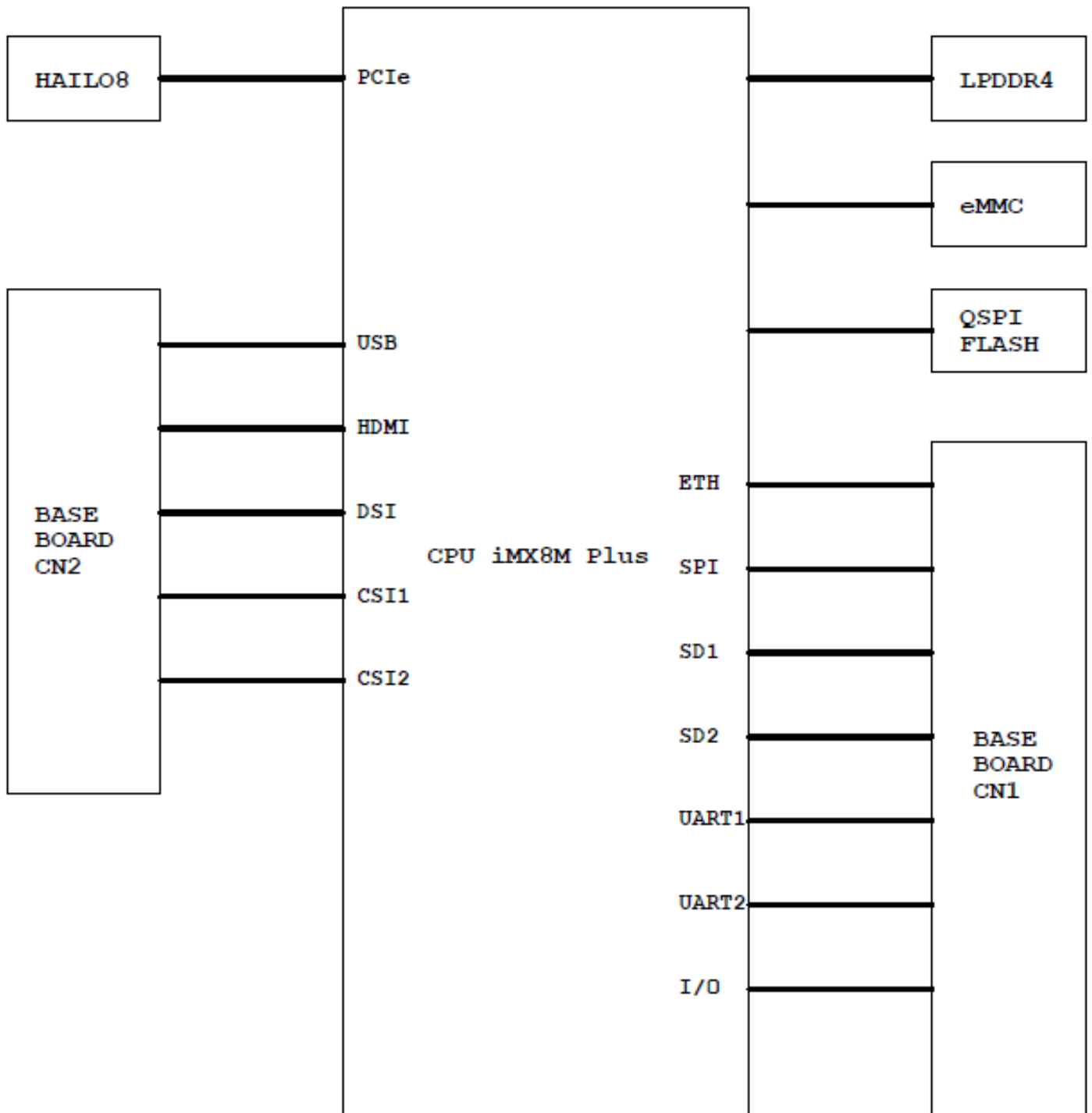

### 3.4.4.3 Alternative function assignments

Up to six alternative functions are available.  
 The NXP i.MX8M Plus Peripherals Manual describes these features in detail.  
 The following table provides a quick overview

Pinout Astrial		
Pin	Signal	Description
1	GND	Ground (0V)
2	GND	Ground (0V)
3	Ethernet_Pair3_P	Ethernet Pair 3 Positive (connect to Transformer)
4	Ethernet_Pair1_P	Ethernet Pair 1 Positive (connect to Transformer)
5	Ethernet_Pair3_N	Ethernet Pair 3 Negative (connect to Transformer)
6	Ethernet_Pair1_N	Ethernet Pair 1 Negative (connect to Transformer)
7	GND	Ground (0V)
8	GND	Ground (0V)
9	Ethernet_Pair2_N	Ethernet Pair 2 Negative (connect to Transformer)
10	Ethernet_Pair0_N	Ethernet Pair 0 Negative (connect to Transformer)
11	Ethernet_Pair2_P	Ethernet Pair 2 Positive (connect to Transformer)
12	Ethernet_Pair0_P	Ethernet Pair 0 Positive (connect to Transformer)
13	GND	Ground (0V)
14	GND	Ground (0V)
15	Ethernet_nLED3	Low Active Ethernet Activity indicator (3.3V signal) Typically a Green LED is connected to this pin
16	Ethernet_SYNC_IN	IEEE1588 SYNC Input pin (1.8V signal)
17	Ethernet_nLED2	Low Active Ethernet speed indicator (3.3V signal) Typically a Yellow LED is connected to this pin. A low State indicates the 1Gbit or 100Mbit Link
18	Ethernet_SYNC_OUT	IEEE1588 SYNC Output pin (1.8V signal)
19	N.C.	No Connection
20	N.C.	No Connection
21	PIL_LED_BB_3V3	Low Active Astrial Activity LED.

Pinout Astrial		
Pin	Signal	Description
22	GND	Ground (0V)
23	GND	Ground (0V)
24	GPIO26	GPIO Typically a 3.3V signal but can be a 1.8V signal by connecting GPIO_Vref to 1.8V -> pin iMX8: SD1_DATA2
25	GPIO21	GPIO Typically a 3.3V signal but can be a 1.8V signal by connecting GPIO_Vref to 1.8V -> pin iMX8: SD1_DATA2
26	GPIO19	GPIO Typically a 3.3V signal but can be a 1.8V signal by connecting GPIO_Vref to 1.8V -> pin iMX8: ECSP12_MISO
27	GPIO20	GPIO Typically a 3.3V signal but can be a 1.8V signal by connecting GPIO_Vref to 1.8V -> pin iMX8: ECSP12_MOSI
28	GPIO13	GPIO Typically a 3.3V signal but can be a 1.8V signal by connecting GPIO_Vref to 1.8V -> pin iMX8: SPDIF_EXT_CLK
29	GPIO16	GPIO Typically a 3.3V signal but can be a 1.8V signal by connecting GPIO_Vref to 1.8V -> pin iMX8: SAI2_TXFS
30	GPIO6	GPIO Typically a 3.3V signal but can be a 1.8V signal by connecting GPIO_Vref to 1.8V -> pin iMX8: SAI2_MCLK
31	GPIO12	GPIO Typically a 3.3V signal but can be a 1.8V signal by connecting GPIO_Vref to 1.8V -> pin iMX8: SAI3_MCLK
32	GND	Ground (0V)
33	GND	Ground (0V)
34	GPIO5	GPIO Typically a 3.3V signal but can be a 1.8V signal by connecting GPIO_Vref to 1.8V -> pin iMX8: SD1_DATA7
35	GPIO1	GPIO Typically a 3.3V signal but can be a 1.8V signal by connecting GPIO_Vref to 1.8V. Internal 4.7K pull up to GPIO_Vref -> pin iMX8: SAI5_RXFS
36	GPIO0	GPIO Typically a 3.3V signal but can be a 1.8V signal by connecting GPIO_Vref to 1.8V. Internal 4.7K pull up to GPIO_Vref -> pin iMX8: SAI5_RXC
37	GPIO7	GPIO Typically a 3.3V signal but can be a 1.8V signal by connecting GPIO_Vref to 1.8V -> pin iMX8: SAI2_TXD0
38	GPIO11	GPIO Typically a 3.3V signal but can be a 1.8V signal by connecting GPIO_Vref to 1.8V -> pin iMX8: ECSP11_SCLK
39	GPIO8	GPIO Typically a 3.3V signal but can be a 1.8V signal by connecting GPIO_Vref to 1.8V -> pin iMX8: ECSP11_SS0
40	GPIO9	GPIO Typically a 3.3V signal but can be a 1.8V signal by connecting GPIO_Vref to 1.8V -> pin iMX8: ECSP11_MISO
41	GPIO25	GPIO Typically a 3.3V signal but can be a 1.8V signal by connecting GPIO_Vref to 1.8V -> pin iMX8: SD1_DATA1
42	GND	Ground (0V)
43	GND	Ground (0V)
44	GPIO10	GPIO Typically a 3.3V signal but can be a 1.8V signal by connecting GPIO_Vref to 1.8V -> pin iMX8: ECSP11_MOSI
45	GPIO24	GPIO Typically a 3.3V signal but can be a 1.8V signal by connecting GPIO_Vref to 1.8V -> pin iMX8: SD1_DATA0

**Pinout Astrial**

Pin	Signal	Description
46	GPIO22	GPIO Typically a 3.3V signal but can be a 1.8V signal by connecting GPIO_Vref to 1.8V -> pin iMX8: SD1_CLK
47	GPIO23	GPIO Typically a 3.3V signal but can be a 1.8V signal by connecting GPIO_Vref to 1.8V -> pin iMX8: SD1_CMD
48	GPIO27	GPIO Typically a 3.3V signal but can be a 1.8V signal by connecting GPIO_Vref to 1.8V -> pin iMX8: SD1_DATA3
49	GPIO18	GPIO Typically a 3.3V signal but can be a 1.8V signal by connecting GPIO_Vref to 1.8V -> pin iMX8: ECSPi2_SS0
50	GPIO17	GPIO Typically a 3.3V signal but can be a 1.8V signal by connecting GPIO_Vref to 1.8V -> pin iMX8: SAI2_RXD0
51	GPIO15	GPIO Typically a 3.3V signal but can be a 1.8V signal by connecting GPIO_Vref to 1.8V -> pin iMX8: SAI2_RXC
52	GND	Ground (0V)
53	GND	Ground (0V)
54	GPIO4	GPIO Typically a 3.3V signal but can be a 1.8V signal by connecting GPIO_Vref to 1.8V -> pin iMX8: SD1_DATA6
55	GPIO14	GPIO Typically a 3.3V signal but can be a 1.8V signal by connecting GPIO_Vref to 1.8V -> pin iMX8: SAI2_RXFS
56	GPIO3	GPIO Typically a 3.3V signal but can be a 1.8V signal by connecting GPIO_Vref to 1.8V. Internal 4.7K pull up to GPIO_Vref -> pin iMX8: SAI5_RXD0
57	SD2_CLK	SDCARD Clock signal
58	GPIO2	GPIO Typically a 3.3V signal but can be a 1.8V signal by connecting GPIO_Vref to 1.8V. Internal 4.7K pull up to GPIO_Vref -> pin iMX8: SAI5_MCLK
59	GND	Ground (0V)
60	GND	Ground (0V)
61	SD2_DAT3	SDCARD/eMMC Data3 signal
62	SD2_CMD	SDCARD/eMMC Command signal
63	SD2_DAT0	SDCARD/eMMC Data0 signal
64	N.C.	No Connection
65	GND	Ground (0V)
66	GND	Ground (0V)
67	SD2_DAT1	SDCARD/eMMC Data1 signal
68	N.C.	No Connection
69	SD2_DAT2	SDCARD/eMMC Data2 signal
70	N.C.	No Connection

Pinout Astrial		
Pin	Signal	Description
71	GND	Ground (0V)
72	N.C.	No Connection
73	SD_VDD_Override	Force SDCARD/eMMC interface to 1.8V signalling if set to 3.3V, otherwise leave unconnected. Typically only used if external eMMC is connected
74	GND	Ground (0V)
75	SD_PWR_ON	Output to Power switch for the SDCARD. The Astrial sets this pin High (3.3V) to signal that Power to the SDCARD should be turned on.
76	Reserved	Do not Connect anything to this pin.
77	+5V (Input)	4.75V-5.25V Main power input
78	GPIO_VREF	Must be connected to pins 84 and 86 for 3.3V GPIO or pins 88 and 90 for 1.8V GPIO. This pin cannot be floating or connected to ground
79	+5V (Input)	4.75V-5.25V Main power input
80	SCL0	I2C Clock pin. Typically used for Camera and Display Internal 4.7K pull up to 3.3V
81	+5V (Input)	4.75V-5.25V Main power input
82	SDA0	I2C Data pin. Typically used for Camera and Display Internal 4.7K pull up to 3.3V
83	+5V (Input)	4.75V-5.25V Main power input
84	Astrial 3.3V (Output)	3.3V +/-2.5% Power Output max 300mA per pin for a total of 600mA. This will be powered down during power off or GLOBAL_EN being set low
85	+5V (Input)	4.75V-5.25V Main power input
86	Astrial 3.3V (Output)	3.3V +/-2.5% Power Output max 300mA per pin for a total of 600mA. This will be powered down during power off or GLOBAL_EN being set low
87	+5V (Input)	4.75V-5.25V Main power input
88	Astrial 1.8V (Output)	1.8V +/-2.5% Power Output max 300mA per pin for a total of 600mA. This will be powered down during power off or GLOBAL_EN being set low
89	N.C.	No Connection
90	Astrial 1.8V (Output)	1.8V +/-2.5% Power Output max 300mA per pin for a total of 600mA. This will be powered down during power off or GLOBAL_EN being set low
91	N.C.	No Connection
92	N.C.	No Connection
93	RPIBOOT_N	A low on this pin disables booting from Astrial internal eMMC. If not used leave floating.
94	N.C.	No Connection
95	P_ON_LED_BB	Low active Output to drive Power On LED.

**Pinout Astrial**

Pin	Signal	Description
96	N.C.	No Connection
97	Camera_GPIO	Typically used to Shutdown the camera to reduce power.
98	GND	Ground (0V)
99	GLOBAL_EN	Input. Drive low to power off Astrial. Internally pulled up with a 100K to +1.8V
100	POR_B_3V3	Output Driven low during reset. Driven high 3.3V once Astrial CPU has finished to boot
101	USB_OTG_ID	Input (3.3V signal) USB OTG Pin. Internal pulled up. When grounded the Astrial becomes a USB host but the correct OS driver also needs to be used
102	N.C.	No Connection
103	USB_N	USB D-
104	N.C.	No Connection
105	USB_P	USB D+
106	N.C.	No Connection
107	GND	Ground (0V)
108	GND	Ground (0V)
109	N.C.	No Connection
110	N.C.	No Connection
111	N.C.	No Connection
112	N.C.	No Connection
113	GND	Ground (0V)
114	GND	Ground (0V)
115	CAM1_D0_N	Input Camera1 D0 Negative
116	N.C.	No Connection
117	CAM1_D0_P	Input Camera1 D0 Positive
118	N.C.	No Connection
119	GND	Ground (0V)
120	GND	Ground (0V)
121	CAM1_D1_N	Input Camera1 D1 Negative
122	N.C.	No Connection



Pinout Astrial		
Pin	Signal	Description
123	CAM1_D1_P	Input Camera1 D1 Positive
124	N.C.	No Connection
125	GND	Ground (0V)
126	GND	Ground (0V)
127	CAM1_C_N	Input Camera1 Clock Negative
128	CAM0_D0_N	Input Camera0 D0 Negative
129	CAM1_C_P	Input Camera1 Clock Positive
130	CAM0_D0_P	Input Camera0 D0 Positive
131	GND	Ground (0V)
132	GND	Ground (0V)
133	CAM1_D2_N	Input Camera1 D2 Negative
134	CAM0_D1_N	Input Camera0 D1 Negative
135	CAM1_D2_P	Input Camera1 D2 Positive
136	CAM0_D1_P	Input Camera0 D1 Positive
137	GND	Ground (0V)
138	GND	Ground (0V)
139	CAM1_D3_N	Input Camera1 D3 Negative
140	CAM0_C_N	Input Camera0 Clock Negative
141	CAM1_D3_P	Input Camera1 D3 Positive
142	CAM0_C_P	Input Camera0 Clock Positive
143	N.C.	No Connection
144	GND	Ground (0V)
145	N.C.	No Connection
146	N.C.	No Connection
147	N.C.	No Connection
148	N.C.	No Connection
149	N.C.	No Connection

**Pinout Astrial**

Pin	Signal	Description
150	GND	Ground (0V)
151	HDMI_CEC	Input HDMI CEC Internally pulled up with a 27K. 5V tolerant (It can be connected directly to an HDMI connector; a small amount of ESD protection is provided on the Astrial by an on board HDMI05-CL02F3)
152	N.C.	No Connection
153	HDMI_HOTPLUG	Input HDMI Hotplug Internally pulled down 100K. 5V tolerant. (It can be connected directly to an HDMI connector; a small amount of ESD protection is provided on the Astrial by an on board HDMI05-CL02F3)
154	N.C.	No Connection
155	GND	Ground (0V)
156	GND	Ground (0V)
157	N.C.	No Connection
158	N.C.	No Connection
159	N.C.	No Connection
160	N.C.	No Connection
161	GND	Ground (0V)
162	GND	Ground (0V)
163	N.C.	No Connection
164	N.C.	No Connection
165	N.C.	No Connection
166	N.C.	No Connection
167	GND	Ground (0V)
168	GND	Ground (0V)
169	N.C.	No Connection
170	HDMI_TX2_P	Output HDMI TX2 Positive
171	N.C.	No Connection
172	HDMI_TX2_N	HDMI Output TX2 Negative
173	GND	Ground (0V)
174	GND	Ground (0V)

Pinout Astrial		
Pin	Signal	Description
175	DSI_D0_N	Output Display D0 Negative
176	HDMI_TX1_P	Output HDMI TX1 Positive
177	DSI_D0_P	Output Display D0 Positive
178	HDMI_TX1_N	Output HDMI TX1 Negative
179	GND	Ground (0V)
180	GND	Ground (0V)
181	DSI_D1_N	Output Display D1 Negative
182	HDMI_TX0_P	Output HDMI TX0 Positive
183	DSI_D1_P	Output Display D1 Positive
184	HDMI_TX0_N	Output HDMI TX0 Negative
185	GND	Ground (0V)
186	GND	Ground (0V)
187	DSI_C_N	Output Display Clock Negative
188	HDMI_CLK_P	Output HDMI Clock Positive
189	DSI_C_P	Output Display Clock Positive
190	HDMI_CLK_N	Output HDMI Clock Negative
191	GND	Ground (0V)
192	GND	Ground (0V)
193	DSI_D2_N	Output Display D2 Negative
194	DSI_D3_N	Output Display D3 Negative
195	DSI_D2_P	Output Display D2 Positive
196	DSI_D3_P	Output Display D3 Positive
197	GND	Ground (0V)
198	GND	Ground (0V)
199	HDMI_SDA	Bidir HDMI SDA Internally pulled up with a 1.8K. 5V tolerant. (It can be connected directly to an HDMI connector; a small amount of ESD protection is provided on the Astrial by an on board HDMI05-CL02F3)
200	HDMI_SCL	Bidir HDMI SCL Internally pulled up with a 1.8K. 5V tolerant. (It can be connected directly to an HDMI connector; a small amount of ESD protection is provided on the Astrial by an on board HDMI05-CL02F3)

Pinout i.Mx8MP Astrial			
iMX8 pin connection	pin iMX8	Default	Default func
I2C6_SDA	SAI5_RXC	ALT5	gpio3.IO[20]
I2C6_SCL	SAI5_RXFS	ALT5	gpio3.IO[19]
I2C5_SDA	SAI5_MCLK	ALT5	gpio3.IO[25]
I2C5_SCL	SAI5_RXD0	ALT5	gpio3.IO[21]
UART3_TX	SD1_DATA6	ALT5	gpio2.IO[8]
UART3_RX	SD1_DATA7	ALT5	gpio2.IO[9]
FCAN2_RX	SAI2_MCLK	ALT5	gpio4.IO[27]
FCAN2_TX	SAI2_TXD0	ALT5	gpio4.IO[26]
ECSPI1_SS0	ECSPI1_SS0	ALT5	gpio5.IO[9]
ECSPI1_MISO	ECSPI1_MISO	ALT5	gpio5.IO[8]
ECSPI1_MOSI	ECSPI1_MOSI	ALT5	gpio5.IO[7]
ECSPI1_SCLK	ECSPI1_SCLK	ALT5	gpio5.IO[6]
OUT_PWM_4	SAI3_MCLK	ALT5	gpio5.IO[2]
OUT_PWM_0	SPDIF_EXT_CLK	ALT5	gpio5.IO[5]
UART1_TX	SAI2_RXFS	ALT5	gpio4.IO[21]
UART1_RX	SAI2_RXC	ALT5	gpio4.IO[22]
UART1_CTS	SAI2_TXFS	ALT5	gpio4.IO[24]
UART1_RTS	SAI2_RXD0	ALT5	gpio4.IO[23]
ECSPI2_SS0	ECSPI2_SS0	ALT5	gpio5.IO[13]
ECSPI2_MISO	ECSPI2_MISO	ALT5	gpio5.IO[12]
ECSPI2_MOSI	ECSPI2_MOSI	ALT5	gpio5.IO[11]
ECSPI2_SCLK	ECSPI2_SCLK	ALT5	gpio5.IO[10]
SD1_CLK	SD1_CLK	ALT5	gpio2.IO[0]
SD1_CMD	SD1_CMD	ALT5	gpio2.IO[1]
SD1_DATA0	SD1_DATA0	ALT5	gpio2.IO[2]
SD1_DATA1	SD1_DATA1	ALT5	gpio2.IO[3]
SD1_DATA2	SD1_DATA2	ALT5	gpio2.IO[4]
SD1_DATA3	SD1_DATA3	ALT5	gpio2.IO[5]
I2C2_SDA_H	I2C2_SDA	ALT5	gpio5.IO[17]
I2C2_SCL_H	I2C2_SCL	ALT5	gpio5.IO[16]

#### 3.4.4.4 HDMI 2.0

Astrial supports an HDMI 2.0 interface capable of handling 4K images.

The HDMI output can be managed up to 4Kp30, however if only the HDMI0 interface is used, images up to 4Kp60 are possible.

HDMI signals must be routed as 100Ω differential pairs.

Each signal, within a pair, should ideally be matched to a value smaller than 0.20 mm.

CEC is also supported; an internal 27 kΩ pull-up resistor is included in the CM4.

Integrated basic ESD protection is provided for I2C EDID and CEC signals; internal pull-up and pulldown resistors are also provided.

#### 3.4.4.5 CSI-2 (MIPI serial camera)

ASTRIAL supports two camera ports: CAM0 (2 lanes) and CAM1 (4 lanes).

CSI signals must be routed as 100Ω differential pairs. Each signal, within a pair, should ideally be matched to a value smaller than 0.20 mm.

Documentation for the CSI interface can be found in the Astrial circuit diagram rev. 3.0 viewable at [systemelectronics.ai](http://systemelectronics.ai), while the Linux kernel drivers can be found at [systemelectronics.ai](http://systemelectronics.ai).

#### 3.4.4.6 DSI-2 (MIPI serial camera)

ASTRIAL supports one display port: DISP1 (4 lanes), which supports a maximum data rate per lane of 1 Gbps.

Although Linux kernel drivers are available, the DSI interface is currently not documented. Only DSI displays supported by official ASTRIAL firmware are supported. DSI signals should be routed as 100 Ω differential pairs; each signal within a pair should ideally be matched at a distance smaller than 0.20 mm.

#### 3.4.4.7 I2C (SDA0 SCL0)

The internal I2C bus is normally assigned to CSI1 and DS11, as these devices are controlled by the firmware. It can be used as a general I2C bus if the CSI1 and DS11 interfaces are not used or are controlled by the firmware. For example, libcamera runs on ARM and does not use firmware, so in this case you can use CSI1 and this I2C bus. SDA0 is connected to gpio5.IO[17] and SCL0 is connected to gpio5.IO[16] as per table at page 3-17.

### 3.4.4.8 I2C (ID\_SD ID\_SC)

The I2C bus is normally used to identify HATs and to control the CSI0 and DSIO devices. If the firmware does not use the I2C bus, e.g. CSI0 and DSIO are not used, these pins can be used as gpio3.I0[20] and gpio3.I0[19], if required as per table at page 3-17.

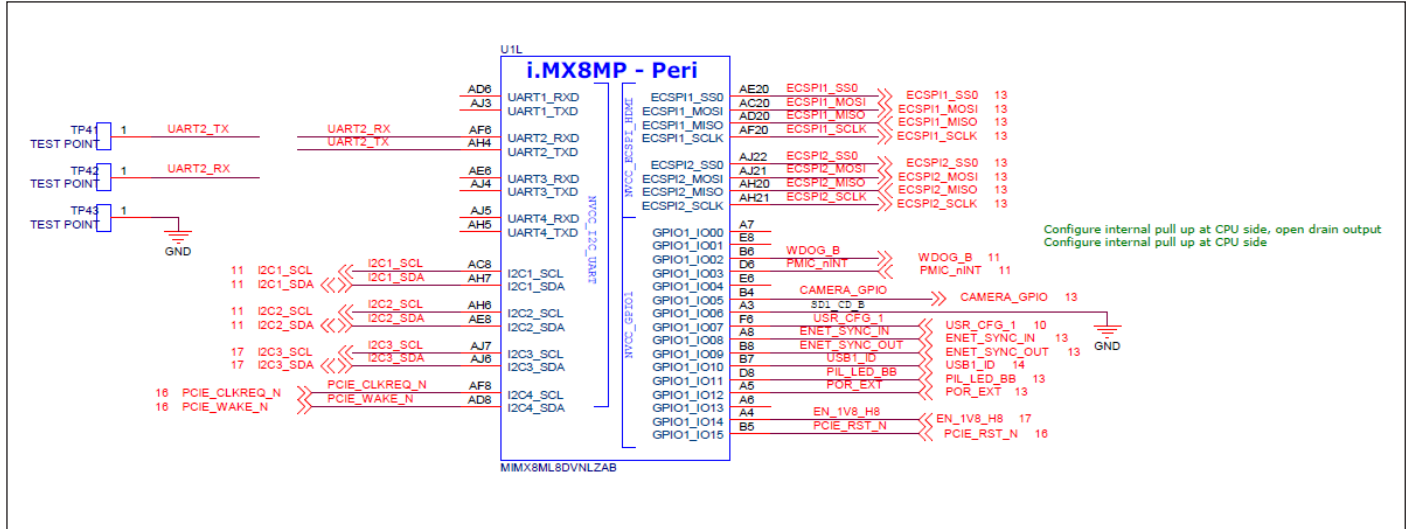

### 3.4.4.9 SDIO/eMMC (32Gb eMMC memory)

ASTRIAL has 32Gb eMMC memory on board. In addition, an eMMC port is available at ASTRIAL's external connector, which can be used to add another eMMC or an external SD card to the carrier. See more details about the SDIO/eMMC and i.MX8M connection on the electrical schematic at [systemelectronics.ai](http://systemelectronics.ai)

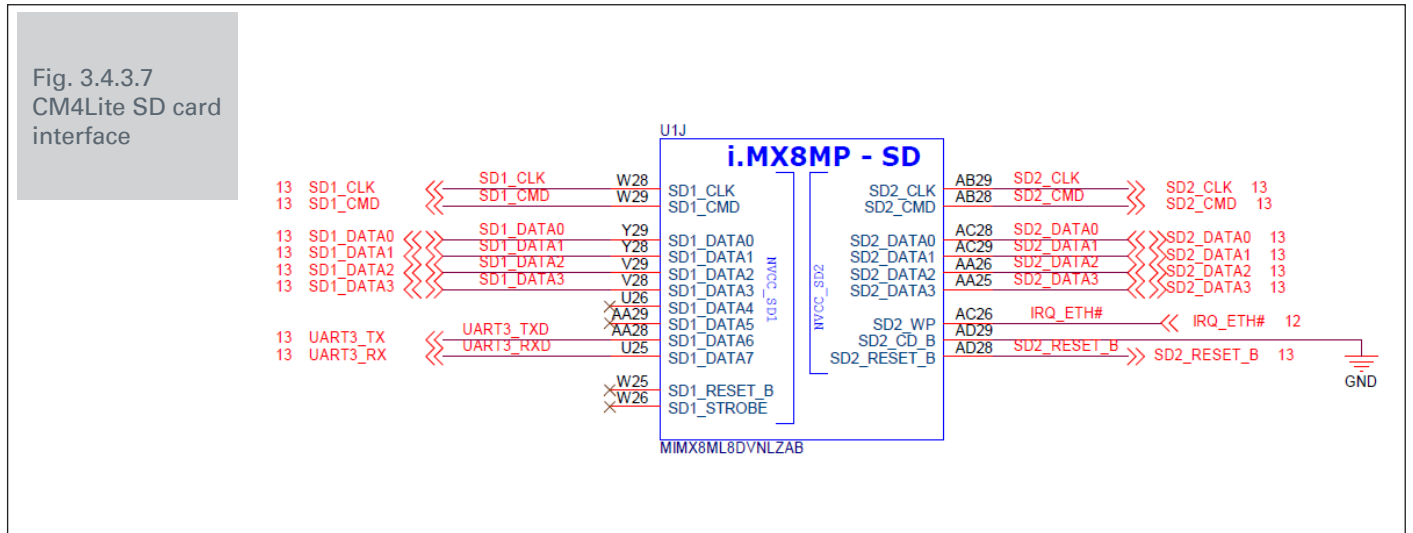

SD0 is brought to the base-board, conversely SD1 is brought to the CM4 Carrier Hat.

#### 3.4.4.10 Analogue IP0/IP1

##### NOTES

*The ASTRIAL Module does not have an analogue interface*

#### 3.4.4.11 RPI\_BOOT\_N

Booting from the eMMC will be interrupted if this pin is low at the time, and the boot will be transferred to the RPI boot, which is performed via USB. The RPI pin is supported by several Options including fast boot.

### 3.5 Mechanical and electrical specifications

#### 3.5.1 Mechanical

ASTRIAL is a compact module measuring 40 × 55 × 4.7 mm. Its actual height is 4.7 mm, but once connected the overall height will be either 5.078 mm or 6.578 mm depending on the stacking height.

The overall dimensions and mounting dimensions are shown in the figure

- Four M 2.5 holes (3.5 mm from the edge of the module)
- Thickness of the PCB: 1.2 mm ± 10%
- Height of the SoC i.MX8M Plus including solder balls 2.378 ± 0.11 mm
- Height including anchoring connectors to the carrier board:
  - a. 1.5 mm with mating connector (clearance under CM4 0 mm): DF40C-100DS-0.4 V
  - b. 3.0 mm with mating connector (free space under CM4 1.5 mm): DF40HC(3.0)-100DS-0.4 V

Fig. 3.5.1  
Overall dimensions  
and mounting  
dimensions

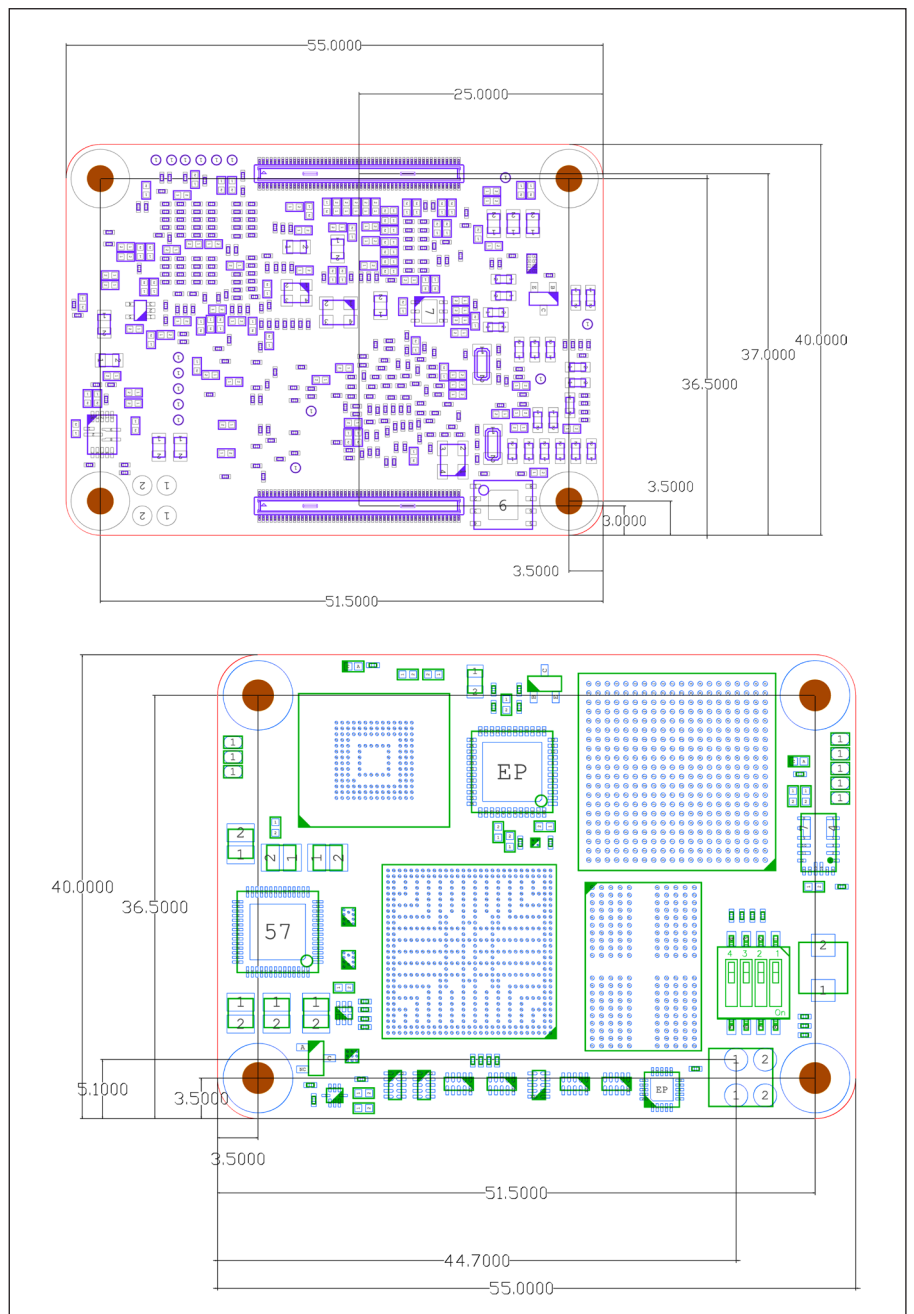

#### NOTES

*The location and arrangement of components on the Compute Module may change slightly over time due to revisions for cost and production considerations; however, the maximum height of the components and the thickness of the PCB will remain as specified.*

#### NOTES

*The STEP file (.stp) is available on [systemelectronics.ai](http://systemelectronics.ai) for further information.*



### 3.5.2 Thermal protection

Astrial in CM4 format dissipates less power than the CM4 Model B. Astrial also contains less metal in the PCB and fewer connectors, which means it has less passive heat dissipation than the CM4 Model B. Although it consumes less power, it may heat up more than the CM4 Model B.

The i.MX8M Plus will reduce the clock frequency to try to keep its internal temperature below 85 °C. Therefore, at high ambient temperatures, the clock may also be automatically reduced. If the i.MX8M Plus is not able to lower its internal clocks enough to lower the temperature, its case temperature will rise above 85 °C.

Operating temperature range: -20 °C - +85 °C without condensation. N.B. Optimum RF wireless performance is between -20 °C and +75 °C.

Astrial was born as a SoM without the need for forced cooling with additional fans. The product was extensively tested with the heatsink (code 80162873) at an operating temperature of 35°C without any crashes or performance limitations.

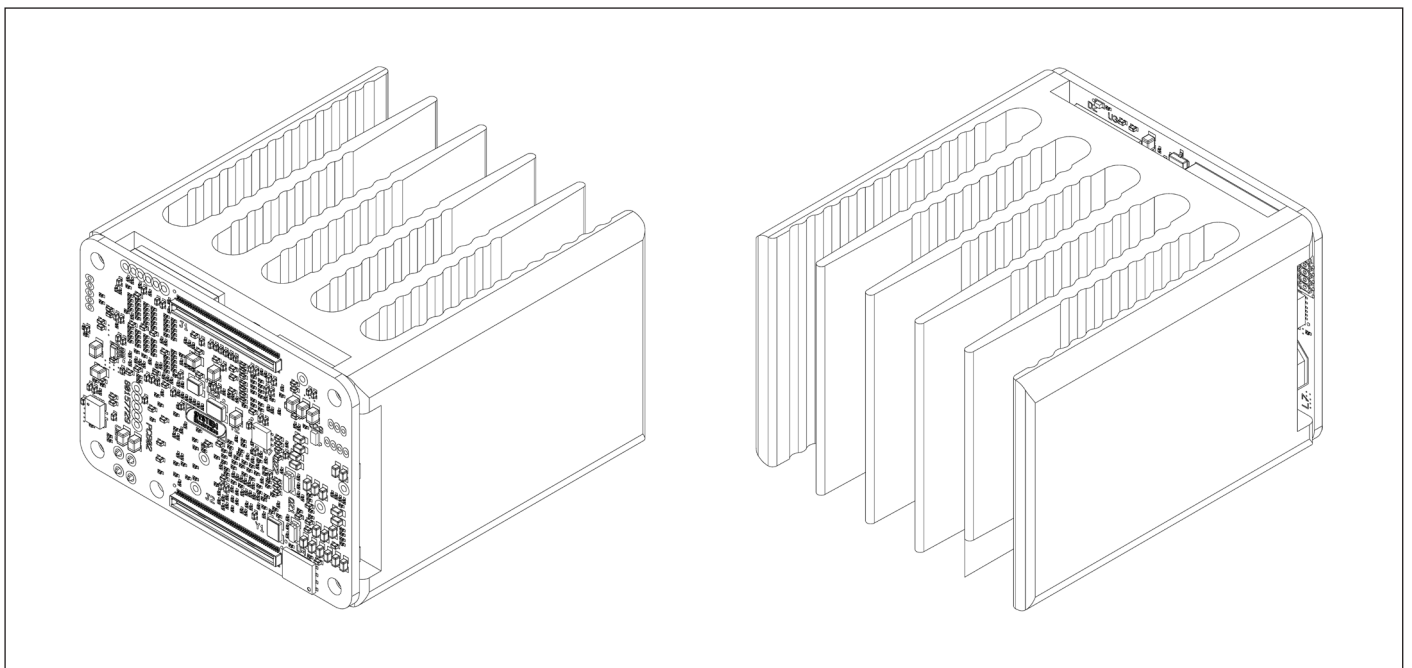

### 3.5.3 Electrical specifications

**WARNING!**

*Stresses exceeding those listed in the table below may cause permanent damage to the Module. This is only an evaluation of stresses; operation of the Module under these or other conditions beyond those listed in the operating sections of this specification is not implied.  
Exposure to conditions of absolute maximum ratings for extended periods can affect the reliability of the Module*

Absolute maximum ratings				
Symbol	Parameter	Minimum	Maximum	Unit
$V_{IN}$	5 V Input Voltage	-0.3	6.0	V
$V_{GPIO\_VREF}$	GPIO Voltage	-0.3	3.6	V
$V_{gpio}$	GPIO Input voltage	-0.3	$V_{GPIO\_VREF} + 0.3$	V

**NOTES**

$V_{GPIO\_VREF}$  is the voltage of the GPIO bank, which must be connected to the 3.3 V or 1.8 V rail of the CM4.

Absolute maximum ratings						
Symbol	Parameter	Conditions	Minimum	Typical	Maximum	Unit
$V_{IL(gpio)}$	Input low voltage	$V_{GPIO\_VREF} = 3.3V$	0	-	0.8	V
$V_{IH(gpio)}$	Input high voltage	$V_{GPIO\_VREF} = 3.3V$	2.0	-	$V_{GPIO\_VREF}$	V

### 3.5.4 Note on the use of Astrial

The PCIe peripheral of i.MX8M is used to make the 2 integrated chips, i.MX8M Plus and hailo 8, communicate. Hailo 8 requires a supply voltage of 5V to function properly. Further information on the Hailo chip can be found on its website <https://hailo.ai/>

## 4. Reception and storage of the product

### 4.1 Checking the content

Upon receipt of the goods, check that the packaging and contents are not visibly damaged. In case of damage or missing parts, notify the carrier and/or contact SYSTEM ELECTRONICS immediately and provide photographic documentation.

#### Packaging

Small quantities are supplied in individual cardboard boxes. These have an internal ESD coating, so there is no need for a separate ESD bag.

This packaging is recyclable and reduces waste.

### 4.2 Storage

In the event of prolonged inactivity, the ASTRIAL must be stored in accordance with the requirements below.

- The location must be enclosed, dry and the packaging must be raised at least 10 cm off the ground.
- The storage temperature should be between  $T=-10^{\circ}\text{C}$  and  $T=+50^{\circ}\text{C}$ , with a relative humidity not exceeding 60% at  $T=-10^{\circ}\text{C}$  and not exceeding 20% at  $T=+50^{\circ}\text{C}$ . In case of significant temperature changes, the temperature gradient must be below  $10^{\circ}\text{C/h}$ .
- The site must be free from vibrations.
- Protect the packaging from the weather, impacts and contact with corrosive substances.
- If possible, keep the product in its original packaging

#### CAUTION!

- *Do not rest heavy objects on top of the packaging*
- *If the packaging has been removed, keep the ASTRIAL in a covered room that provides protection from the weather, aggressive chemicals and impacts.*

## 4.3 Assembly and disassembly

### WARNING!

- *Operation of the ASTRIAL Module is only permitted inside a closed enclosure (e.g. electrical cabinet with an IP 55 protection rating against dust and liquids).*
- *The installation of the Module in a metal cabinet protected by equivalent safety measures is intended to prevent flames and emissions from spreading outside the enclosure.*
- *To ensure efficient air flow inside the enclosure, it is advisable to fit the ASTRIAL vertically and sufficient space must be provided for ventilation from the underside.*
- *The ambient temperature in storage must be between 0°C and + 50°C*

## 5. Connections

### 5.1 Safety instructions

**WARNING!**

*Before operating, make sure you understand all the safety information in paragraph 1.3*

### 5.2 Lengths of the differential torque signal from 100 Ω clearance distances

On the CM4, all differential pairs are matched at a distance smaller than 0.20 mm (P/N signals).

**NOTES**

*It is also recommended to match the pairs on the interface board.*

On the CM4, pairs are not always matched, as many interfaces do not require the accurate matching of pairs. The table shows the difference of length of the trace in each group (a non-zero value represents how much longer that trace is in mm, compared to the signal with a zero difference of length).

Lengths of the differential torque signal from 100 Ω			
Signal	Length	Signal	Length
CAM0_C_N MPI_CSL1_CLK_N	0.02	DSI0_C_N	0
CAM0_C_P MPI_CSL1_CLK_P	0.02	DSI0_C_P	0
CAM0_D0_N MPI_CSL1_CLK_N	0.06	DSI0_D0_N	0
CAM0_D0_P MPI_CSL1_CLK_P	0.07	DSI0_D0_P	0
CAM0_D1_N MPI_CSL1_CLK_N	0	DSI0_D1_N	0.01
CAM0_D1_P MPI_CSL1_CLK_P	0.01	DSI0_D1_P	0.01
CAM0_D2_N MPI_CSL2_D2_N	0.05	DSI0_D2_N	0.83
CAM0_D2_P MPI_CSL2_D2_P	0.04	DSI0_D2_P	0.84
CAM0_D3_N MPI_CSL2_D3_N	0.01	DSI0_D3_N	3.78
CAM0_D3_P MPI_CSL2_D3_P	0	DSI0_D3_P	3.79
CAM1_C_N MPI_CSL2_CLK_N	0.78	DSI1_C_N	1.28
CAM1_C_P MPI_CSL2_CLK_P	0.78	DSI1_C_P	1.28
CAM1_D0_N MPI_CSL2_D0_N	0.02	DSI1_D0_N	0
CAM1_D0_P MPI_CSL2_D0_P	0.01	DSI1_D0_P	0.01
CAM1_D1_N MPI_CSL2_D1_N	0.4	DSI1_D1_N	1.06
CAM1_D1_P MPI_CSL2_D1_P	0.4	DSI1_D1_P	1.06
CAM1_D2_N MPI_CSL2_D2_N	0.05	DSI1_D2_N	0.83
CAM1_D2_P MPI_CSL2_D2_P	0.04	DSI1_D2_P	0.84
CAM1_D3_N MPI_CSL2_D3_N	0.01	DSI1_D3_N	3.78
CAM1_D3_P MPI_CSL2_D3_P	0	DSI1_D3_P	3.79
HDMI0_CLK_N	3.25	Ethernet_Pair0_P	5.23
HDMI0_CLK_P	3.24	Ethernet_Pair0_N	5.23
HDMI0_TX0_N	1.76	Ethernet_Pair1_P	0
HDMI0_TX0_P	1.76	Ethernet_Pair1_N	0
HDMI0_TX1_N	0.62	Ethernet_Pair2_P	3.82
HDMI0_TX1_P	0.62	Ethernet_Pair2_N	3.82
HDMI0_TX2_N	0	Ethernet_Pair3_P	4.29
HDMI0_TX2_P	0	Ethernet_Pair3_N	4.29

### 5.3 Lengths of the differential torque signal from 90 $\Omega$

On the CM4, all differential pairs are matched at a precision greater than 0.05 mm (P/N signals).

#### NOTES

*It is also recommended to match the pairs on the interface board.*

The table shows the difference of length of the trace CM4 in each group (a non-zero value represents how much longer that trace is in mm, compared to the signal with a zero difference of length).

Lengths of the differential torque signal from 90 $\Omega$	
Signal	Length
USB2_P	0
USB2_N	0

## 6. Operating Instructions

### 6.1 Switch-on sequence

ASTRIAL requires a single +5 V power supply and can supply up to 600 mA at +3.3 V and +1.8 V to the peripherals. All pins must have no power applied before the +5 V rail is applied.

If ASTRIAL is started up via a USB connection, the RPIBOOT\_N signal must have a rise-time within 2ms to comply with the 5V power sequence.

+5V should monotonically increase to 4.75 V and remain above 4.75 V for the entire operation of the CM4.

The switch-on sequence will start when both +5V rails are above 4.75 V and GLOBAL\_EN increases. GLOBAL\_EN has an internal RC delay so that it increases after +5 V has increased.

The order of events is as follows:

1. +5V increases
2. GLOBAL\_EN increases
3. +3.3 V increases
4. +1.8 V increases at least 1 ms after +3.3 V
5. RUN\_PG increases at least 10 ms after +1.8 V
6. EXT\_nRESET increases at least 1 s after RUN\_PG

### 6.2 Switch-off sequence

The operating system should be switched off before removing power to ensure that the file system remains consistent. If this cannot be achieved, then a file system such as btrfs, f2fs or overlayfs should be considered (use raspi-config to enable this).

Once the operating system has shut down, the GLOBAL\_EN pin can be brought low to put the CM4 in the lowest power mode, or the +5 V rail can be removed.

During the switch-off sequence, the +1.8 V will be discharged before the +3.3 V rail.

### 6.3 Energy consumption

The exact power consumption of the CM4 will largely depend on the activities performed on the CM4. The lowest switch-off power consumption mode is with GLOBAL\_EN driven low, typically 15  $\mu$ A.

With GLOBAL\_EN high but the software switched off, typical consumption is 8 mA. Idle energy consumption is typically 400 mA, but varies greatly depending on the operating system. Operating energy consumption is typically around 1.4 A; again, this depends largely on the operating system and the tasks performed.

## 6.4 Regulator outputs

To simplify the interface with the CM4, the on-board regulators (+3.3 V and +1.8 V) can each supply 600 mA to the devices connected to the CM4. Loads on these outputs are not taken into account in the energy consumption figures.

## 6.5 Hailo 8

Hailo 8 is an AI accelerator, capable of up to 26 TOPS, that communicates with the i.Mx8mp via PCIe bus. For more information about Hailo 8, visit the official website <https://hailo.ai/products/ai-accelerators/hailo-8-ai-accelerator/>

## 6.6 Software

### Astrial OS

The operating system of the Astrial board is based on the yocto distribution and is available on the official github of System Electronics - GitHub

This distribution is carried out using the official software provided by NXP available at [nxp-imx - GitHub](https://github.com/nxp-imx)

The guide to building the image and on initial use of the board can be found at the following link <https://github.com/System-Electronics/astrial-howto>



## 7. Maintenance and disposal

### DANGER!

*Any intervention on the ASTRIAL be carried out in the absence of power supply.  
The module remains live even for a long time when the power supply is disconnected.*

### 7.1 Routine maintenance

Check the Module and clean the contacts and printed circuit boards, paying particular attention to their condition. Remove dust using dry air jets.

Do not use water, petrol or other flammable solvents, always use non-toxic commercial solvents.

Do not use dirty, stringy or abrasive rags.

### CAUTION!

*Take care not to damage the printed circuit boards and/or connector contacts.*

### DANGER!

*Dust can pose a certain danger because it can be rich in electrostatic charges which can interfere, even severely, with operation of the circuit. In addition to dust, oxidation phenomena can occur especially on the feet that fit into the various slots of the equipment. Periodic cleaning of these printed circuit boards is, therefore, necessary in order to keep the equipment in good working order at all times.*

### 7.2 Decommissioning and disposal

### DANGER!

*Switch off the power supply before disconnecting the cables and dismantle the parts to be disposed of*

The Module must be dismantled and disassembled completely before being disposed of.

- Plastic enclosure parts must be taken to a plastic recycling centre.
- Stainless steel parts must be taken to a metal recycling centre.
- Electronic components and/or printed circuit boards must be disposed of in compliance with national regulations for the disposal of electronic products.

### WARNING!

*Dispose of the various materials so that they can be recycled in compliance with the regulations in force in the country of use.  
Nationally, the European Union Act 2018 amended Legislative Decree 49/2014, in compliance with Directive 2012/19/EU on waste electrical and electronic equipment (WEEE).*

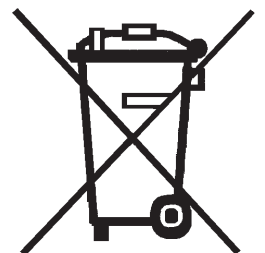



a coesia brand